

KUKA

KUKA Automotive Solutions

KS FRAMER



■ **KS FRAMER**

PERFECT PRECISION – THE KUKA FRAMING STATION

With the framing station, KUKA has developed a product which fully satisfies the requirements with regard to precision and geometry, and which can be easily adapted to different tasks due to its modular design.

The central component is a geometry box, in which the underbody and the clamping frames holding the side panels and roof elements are precisely located. Depending on the specific configuration, 4 to 8 robots are employed to join the body parts in the framing station. The robot mounting bases are mechani-

cally isolated from the geometry box to prevent the transmission of vibrations.

An important feature of the KUKA framing station are the mobile clamping frames, which can be positioned on a linear unit. This means that different clamping frames for various vehicle models can be used in the framing station.

The clamping frames for 3-6 vehicle models are stored in clamping frame magazines with a horizontal axis.

All drives are mounted in a stationary position.

| TECHNICAL DATA | |
|---|--|
| ■ Weight of clamping frame: | Max. 2500 kg |
| ■ Size of clamping frame: | H: max. 2600, W: max. 1600, L: max. 4500 |
| ■ Space requirement with a total of 6 models: | 12 x 22 m |
| ■ Time for clamping frame change: | Max. 23 s |
| ■ Motor of X and Y axes: | SEW asynchronous servomotor |

MAXIMUM SIZE OF THE CLAMPING FRAME

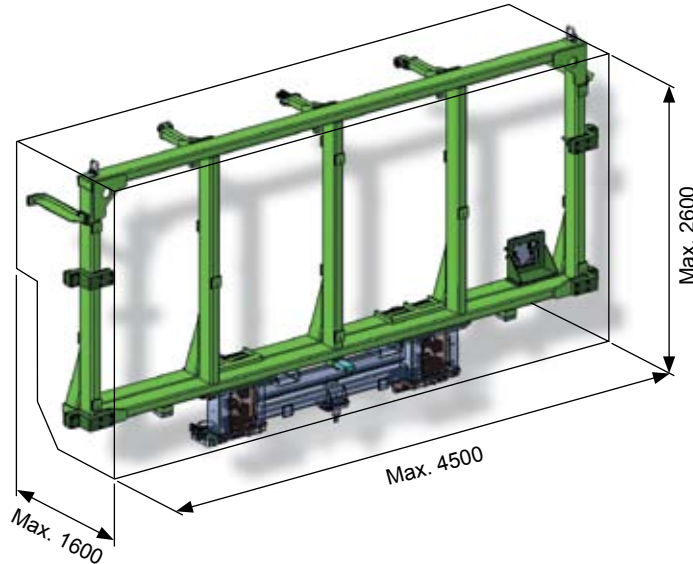

Specifications regarding the quality and usability of the products do not constitute a warranty of properties. They are intended to serve informative purposes only. Solely the respective contract of sale shall be binding in respect of the extent of our supplies and services.

For more details contact us at standard@kuka.de or call + 49 821 797-1757.

KUKA Systems GmbH

Bluecherstrasse 144 | 86165 Augsburg | Germany
 Tel. + 49 821 797-0 | Fax + 49 821 797-1991
 info@kuka.de | www.kuka-systems.com

International

Benelux | Brazil | China | France | Germany | India
 Mexico | Norway | Russia | Slovakia | Sweden | UK | USA

