

# KUKA

KUKA Automotive Solutions

## KS TIP CHANGER KTC



## ■ KS TIP CHANGER KTC

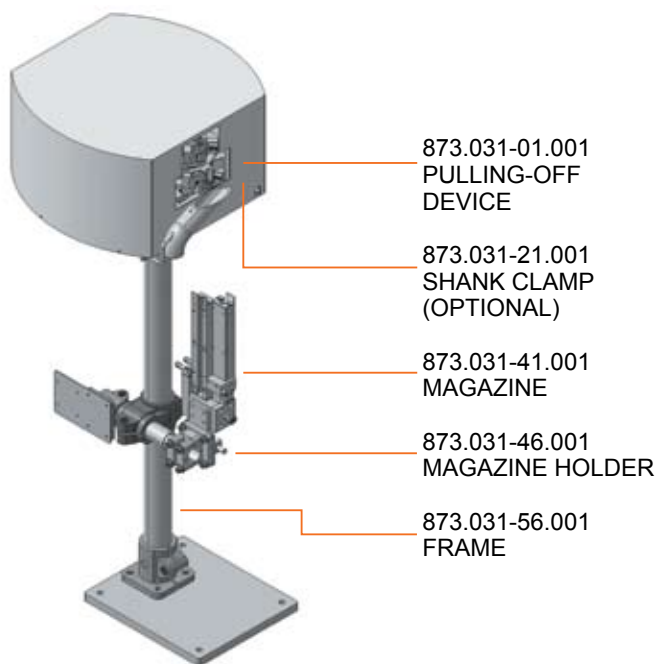

PRINCIPAL DIMENSIONS: W 480 X D 575  
H VARIABLE (STANDARD 1275)

### GENERAL

The tip changing unit is a fully self-contained functional unit with a clear interface. The automatic tip changer makes it possible for worn electrode tips to be changed automatically. The system is designed in such a way that the footprint is minimized, while accessibility for the robot is optimized. The tip changer removes the electrode tip from the shank by means of a combination of radial and axial motion. The removed electrode tips are transferred to a receptacle. Monitoring functions ensure that the tips have been reliably removed from the electrode shanks.

### MAGAZINE FOR ELECTRODE TIPS

The magazine for electrode tips can be easily exchanged by means of a quick-change device.

The magazine can hold 2 x 14 tips. If there are fewer than three tips in the magazine, a warning is triggered. Monitoring functions ensure that the tips are securely fitted on the electrode shank.

### SHANK CLAMP (OPTIONAL)

The optional shank clamp holds the electrode shank while the tip is being pulled off and prevents it from being twisted out of its mount.

### ADVANTAGES

- No gun motion required for the changing operation, space-optimized solution
- No specialist knowledge required on the part of the robot operator
- The process position can be easily reached by the robot from almost any direction
- No special threading operation
- One device for various tip types
- One device for various gun types
- Electrode shank clamp as option

### TECHNICAL DATA

■ Rated voltage	24 V DC
■ Oil-free, filtered compressed air	Min. 4 bar, max. 6 bar
■ Weight of the changing unit	57 kg
■ Time for one changing cycle	24 s
■ Max. electrode shank angle at the gun	0° - 30°
■ Availability	99.9%
■ Maintenance work	Maintenance-free

Specifications regarding the quality and usability of the products do not constitute a warranty of properties. They are intended to serve informative purposes only. Solely the respective contract of sale shall be binding in respect of the extent of our supplies and services.

For more details contact us at [standard@kuka.de](mailto:standard@kuka.de) or call + 49 821 797-1757.

### KUKA Systems GmbH

Bluecherstrasse 144 | 86165 Augsburg | Germany  
Tel. + 49 821 797-0 | Fax + 49 821 797-1991  
[info@kuka.de](mailto:info@kuka.de) | [www.kuka-systems.com](http://www.kuka-systems.com)

### International

Benelux | Brazil | China | France | Germany | India  
Mexico | Norway | Russia | Slovakia | Sweden | UK | USA

# KUKA