

# KUKA

KUKA Automotive Solutions

## KS MULTIFLEX



■ **KS MULTIFLEX**  
**FLEXIBLE COUPLING UNIT**

In order to increase the flexibility of the robot for future applications such as “fine seam sealing of doors”, it is essential that two tools can be operated independently of each other.

KS Multiflex meets this requirement and enables coupling and decoupling of an additional tool in the rotating motion of the robot’s 6th axis where necessary.



**TECHNICAL DATA**

- |                          |   |
|--------------------------|---|
| ■ Weight:                | 7 - 9 kg (depending on design)          |
| ■ Diameter:              | Approx. 200 mm                          |
| ■ Length:                | 200 mm                                  |
| ■ Max. angular velocity: | 320°/s (depending on speed of 6th axis) |
| ■ Max. pressure:         | $p^{\max} = 6 \text{ bar}$              |
| ■ Adaptation to robot:   | KR16, KR60, KR30, ...                   |
- The connections for supply of air and energy and transmission of signals are contained and sealed within the unit, thus allowing utilisation in polluted industrial environments
  - Lifetime bearing lubrication
  - Mounted free from play due to decoupled power transmission through the housing

**OPTIMIZATION OF PROCESS**

- Energy/air supply connections protected and installed in wear-resistant manner
- Improved accessibility since the attached equipment does not change its position relative to the robot’s axis of movement during the application
- Significantly lower strain on energy/air supply lines in the attached equipment, as it moves only when the process is active

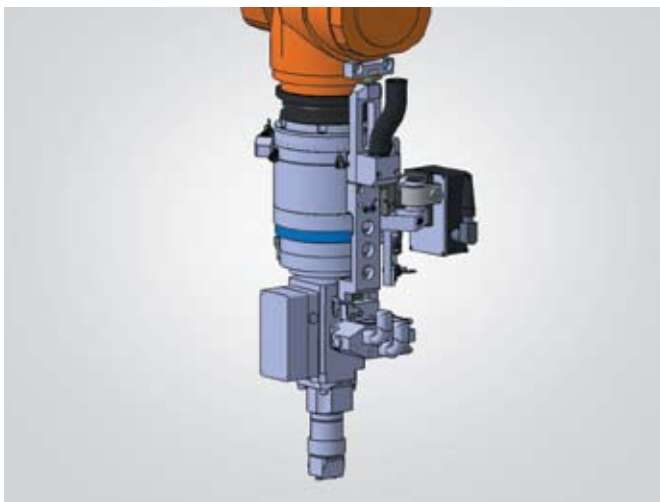

Specifications regarding the characteristics and usability of the products do not constitute a warranty of properties. They are intended to serve informative purposes only. Some items of equipment depicted in the illustrations are optional, and are not included in the standard scope of supply. Solely the respective contract of sale shall be binding in respect of the extent of our supplies.

**KUKA Systems GmbH**

Bluecherstrasse 144 | 86165 Augsburg | Germany  
 Tel. + 49 821 797-0 | Fax + 49 821 797-1991  
 info@kuka.de | www.kuka.com

**International**

Benelux | Brazil | China | France | Germany | India | Mexico  
 Norway | Russia | Slovakia | South Korea | Sweden | UK | USA

**KUKA**