

KUKA

KUKA Automotive Solutions

KS CHAIN MAGAZINE D DOUBLE STRAND



■ **KS CHAIN MAGAZINE D**
DOUBLE STRAND

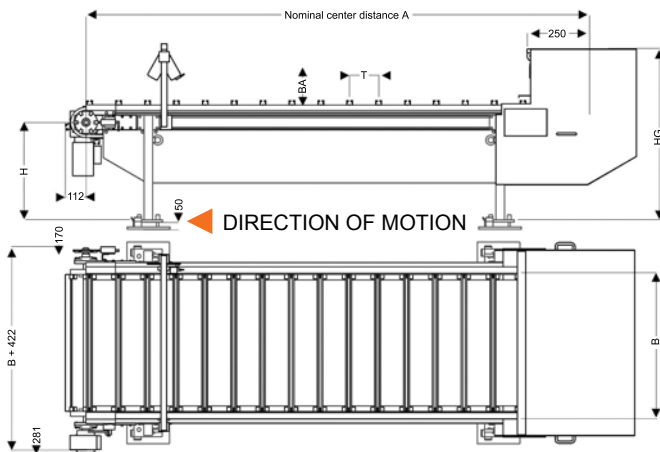
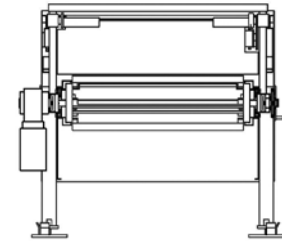
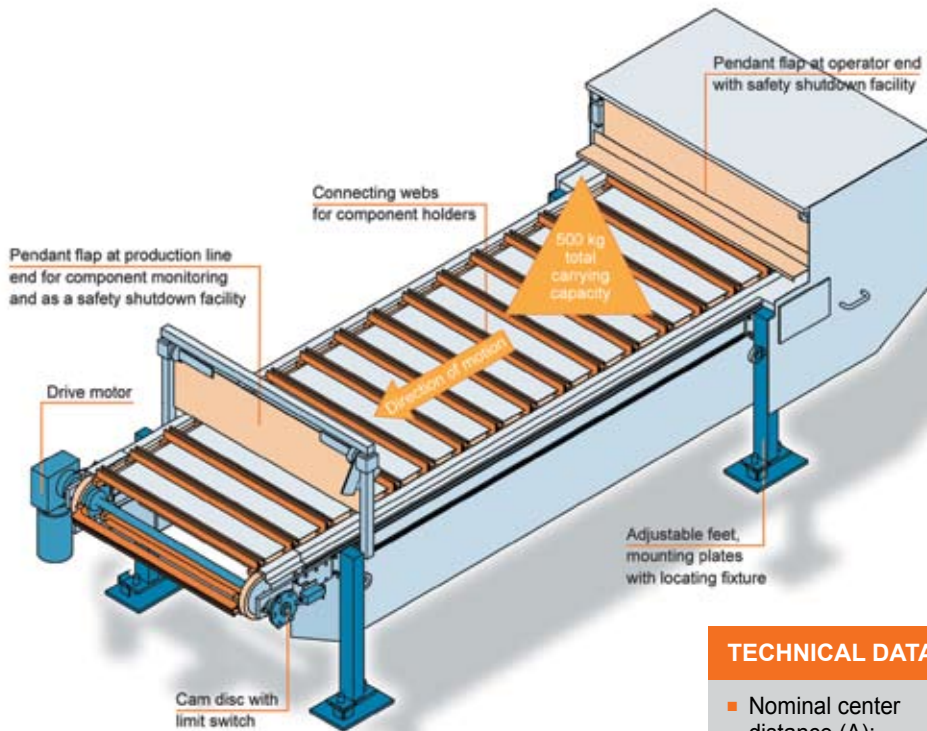

TECHNICAL DATA

■ Nominal center distance (A):	Normal: 1524 - 6236 mm (152 mm steps) Extra long: 6388 - 11556 mm (152 mm steps)
■ Axis height (H):	500 - 1200 mm (50 mm steps)
■ Height of component location (BA):	Max. 245 mm
■ Track width (B):	300 - 2000 mm (100 mm steps)
■ Overall height (HG):	H + 515 mm
■ Component spacing (T): (indexing)	101.6 / 152.4 / 203.2 / 304.8 / 609.6 mm (4", 6", 8", 12", 24")
■ Velocity:	v = 50 mm/s
■ Positioning accuracy:	+/- 0.5 mm
■ Max. carrying capacity:	mT = 500 kg
■ Max. load:	15 kg (per connecting web)
■ Installation position:	Upright (inverted or inclined: optional)

Specifications regarding the quality and usability of the products do not constitute a warranty of properties. They are intended to serve informative purposes only. Solely the respective contract of sale shall be binding in respect of the extent of our supplies and services.

For more details contact us at standard@kuka.de or call + 49 821 797-1757.

KUKA Systems GmbH

Bluecherstrasse 144 | 86165 Augsburg | Germany
Tel. + 49 821 797-0 | Fax + 49 821 797-1991
info@kuka.de | www.kuka-systems.com

International

Benelux | Brazil | China | France | Germany | India
Mexico | Norway | Russia | Slovakia | Sweden | UK | USA

KUKA